

Double Magnetic Suspension

J. W. Beams

Citation: [Review of Scientific Instruments](#) **34**, 1071 (1963); doi: 10.1063/1.1718136

View online: <https://doi.org/10.1063/1.1718136>

View Table of Contents: <http://aip.scitation.org/toc/rsi/34/10>

Published by the [American Institute of Physics](#)

Articles you may be interested in

[Magnetic Suspension for Small Rotors](#)

Review of Scientific Instruments **21**, 182 (1950); 10.1063/1.1745523

[Spinning Rotor Pressure Gauge](#)

Review of Scientific Instruments **33**, 151 (1962); 10.1063/1.1746520



PFEIFFER VACUUM

VACUUM SOLUTIONS FROM A SINGLE SOURCE

Pfeiffer Vacuum stands for innovative and custom vacuum solutions worldwide, technological perfection, competent advice and reliable service.

[Learn more!](#)

THE REVIEW OF SCIENTIFIC INSTRUMENTS

VOLUME 34, NUMBER 10

OCTOBER 1963

Double Magnetic Suspension*

J. W. BEAMS

University of Virginia, Charlottesville, Virginia

(Received 13 June 1963)

A double magnetic suspension is described in which the lower rotor is magnetically suspended from the upper rotor which in turn is magnetically suspended. The upper rotor may be made to surround the lower (or inner) rotor. Consequently, the effective magnetic suspension and vacuum chamber surrounding the inner rotor may be made to spin at approximately the same speed as the inner rotor (or within a few rps). This greatly reduces the rotor's deceleration when it is coasting freely.

A NUMBER of important experiments could be carried out if a constant speed rotor or a rotor which decelerated very slowly could be developed. It has been found that a magnetically suspended rotor decelerates very slowly when spinning in a vacuum.¹ In routine operation the magnetically suspended ultracentrifuge rotor, when coasting freely at 300 rps in air at a pressure between 10^{-6} and 10^{-7} Torr, loses only about 1 rps/day.² All of the measured frictional drag on a properly magnetically suspended rotor can be accounted for as due to air friction down to an air pressure of about 5×10^{-8} Torr. In fact, a magnetically suspended rotor has been used as an absolute pressure gauge down to 5×10^{-8} Torr.³ However, in practice at pressures below this other factors which produce a deceleration of the rotor become important. Some of these factors are (1) residual air pressure; (2) eddy current drag produced by both constant and varying magnetic fields with components perpendicular to the axis of spin; (3) eddy current drag produced by precession of the spin axis resulting from the rotation of the earth; (4) inhomogeneities in the rotor material and in the magnetic properties of the material; (5) induced currents in the surrounding apparatus and material due to magnetic poles in the rotor not exactly on the axis of rotation; (6) damping resulting from electrostatic charges on the rotor and on the vacuum chamber walls; (7) errors in the construction and function-

ing of the solenoid, sensing elements, suspension circuits their mountings, and the rotor; (8) vibrations of building and the earth; (9) vertical or horizontal drifts of the rotor; (10) variations in the rotor temperature; (11) creep of rotor material; (12) pressure of light on rotor; (13) radiometer effects and Brownian motion; (14) variations in direction of gravitational field; and (15) gravitational radiation.

It is found experimentally that with sufficient care the above factors can be reduced to $\dot{f}/f \sim 10^{-9} \text{ sec}^{-1}$ where \dot{f} is the change in rotor speed f per unit of time while the rotor is coasting. This was accomplished by freezing out the residual gas surrounding the rotor with liquid helium and by carefully reducing the effects of the above items from 2 to 12. Fortunately, components of the steady magnetic field perpendicular to the axis of spin which, of course, produce eddy current drag could be greatly reduced because the rotor hangs as a pendulum and the axis of rotation when properly adjusted is almost along the resultant of the steady magnetic field. On the other hand, the varying magnetic fields perpendicular to the axis of spin should be reduced as much as possible by shielding with two or more layers of Permalloy sheets surrounding the apparatus.

With the exception of items from 10 to 15 listed above, the drag is introduced either by the air friction on the rotor or by the magnetic suspension itself. Theory shows that the acceleration or deceleration effects of items 12 to 15 probably are very small and that item 11 also can be made small when the stresses in the rotor are not large. By careful construction of the rotor, temperature effects can be approximately compensated for and thus also its speed-

* Supported by U. S. Army Research Office (Durham) and U. S. Navy Bureau of Weapons grants.

¹ J. W. Beams, J. L. Young, III, and J. W. Moore, *J. Appl. Phys.* **17**, 886 (1946).

² J. W. Beams, R. D. Boyle, and P. E. Hexner, *Rev. Sci. Instr.* **32**, 645 (1961).

³ J. W. Beams, D. M. Spitzer, Jr., and J. P. Wade, Jr., *Rev. Sci. Instr.* **33**, 151 (1962).

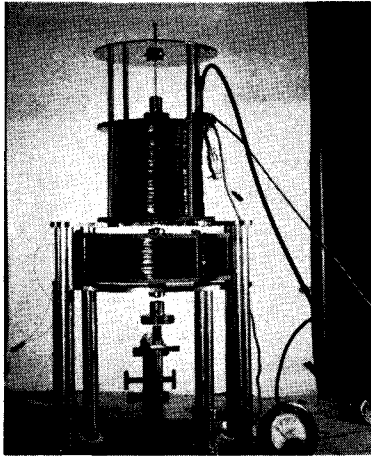

FIG. 1. First type double magnetic suspension. Upper rotor extends through lower solenoid in order to show suspension. It is longer than used in practice. Also "skirts" on upper rotor are absent. Both solenoids exert upward forces.

disturbing effects made small. Therefore, it is obvious that if both the magnetic suspension and the vacuum chamber surrounding the rotor could be made to spin with approximately the same speed (or within a few rps) as the rotor, that the deceleration of the rotor f/f could be made exceedingly minute.⁴ However, this must be done without introducing vibrations, which eliminates the use of mechanical bearings. It has been observed experimentally that f/f is critically affected by mechanical vibrations. The purpose of this paper is to describe a double magnetic suspension in which the rotor is magnetically suspended from an "outer rotor" which in turn is magnetically suspended. If desired, the outer (or upper) rotor may be made to surround the inner (or lower) rotor so that the conditions for a very low f/f mentioned above are fulfilled. So far, the apparatus has been tested only at atmospheric pressure, and relatively low rotor speeds. However, because of the potential use of the double magnetic suspension in other types of experiments, it seems worthwhile to describe it at this time.

Figure 1 and 3 show photographs of double magnetic suspensions and Fig. 2 shows a schematic diagram of the suspensions of Fig. 1. In Figs. 1 and 3, the "skirt" which

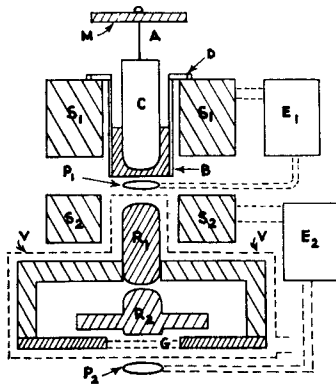

FIG. 2. Schematic diagram of the double magnetic suspension system of Fig. 1.

surrounds R_2 , shown schematically in Fig. 2, is removed in order to show the double suspension. Also the upper (outer) rotor in Fig. 1 is made somewhat longer than used in practice in order to show the suspensions above and below the lower solenoid. In Fig. 2 the upper (outer) rotor R_1 is magnetically suspended by the solenoid S_1 . R_1 is vertically stabilized by the servo-circuit E_1 , which regulates the current through the solenoid S_1 . If R_1 rises, the impedance of the sensing coil P_1 is changed which in turn regulates the servo-circuit in such a way that the current is reduced. If the rotor falls the current in S_1 is automatically increased, etc. If properly adjusted such a circuit will maintain the height of R_1 constant to better than a wavelength of light. The horizontal position of R_1 is maintained by the shape of the symmetrical field; i.e., the strongest field is on the axis and the ferromagnetic rotor R_1 , therefore, will be pulled back to the axis when disturbed. The core of the solenoid S_1 hangs from the support M as a pendulum. Its lower end hangs in a dash pot of oil which damps any horizontal motion of R_1 .

The force which supports the rotor R_1 is proportional to $M\partial H/\partial Z$ where M is the magnetic moment of R_1 and $\partial H/\partial Z$ is the vertical gradient of the magnetic field. Consequently, if a second ferromagnetic rotor R_2 is placed below R_1 it will be attracted upward. If brought close enough the two rotors will fly together. In order to stabilize vertically R_2 a second solenoid S_2 is placed around R_1 in such a way that R_1 essentially becomes the core of S_2 . The sensing coil P_2 and the second servo-support-circuit E_2 regulate the current through S_2 in such a way that R_2 is magnetically supported from R_1 . It will be noted that essentially all of the magnetic flux which supports R_2 originates from R_1 . It should be mentioned that the magnetic moments of R_1 and R_2 are changed by changes in current through either S_1 or S_2 . However, it is found in practice that both R_1 and R_2 are supported very stably when the servo-circuits are properly adjusted. The "skirt" of rotor R_1 is made of nonferromagnetic material although this might not always be necessary. The dotted line in R_1 is a nonconducting window. For adjustment purposes it is convenient to place transparent windows or radial channels

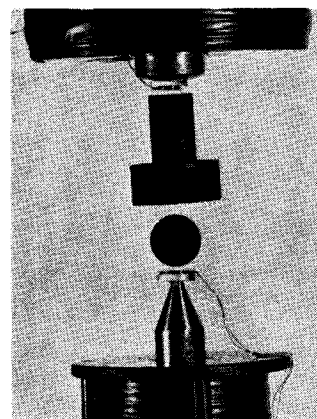
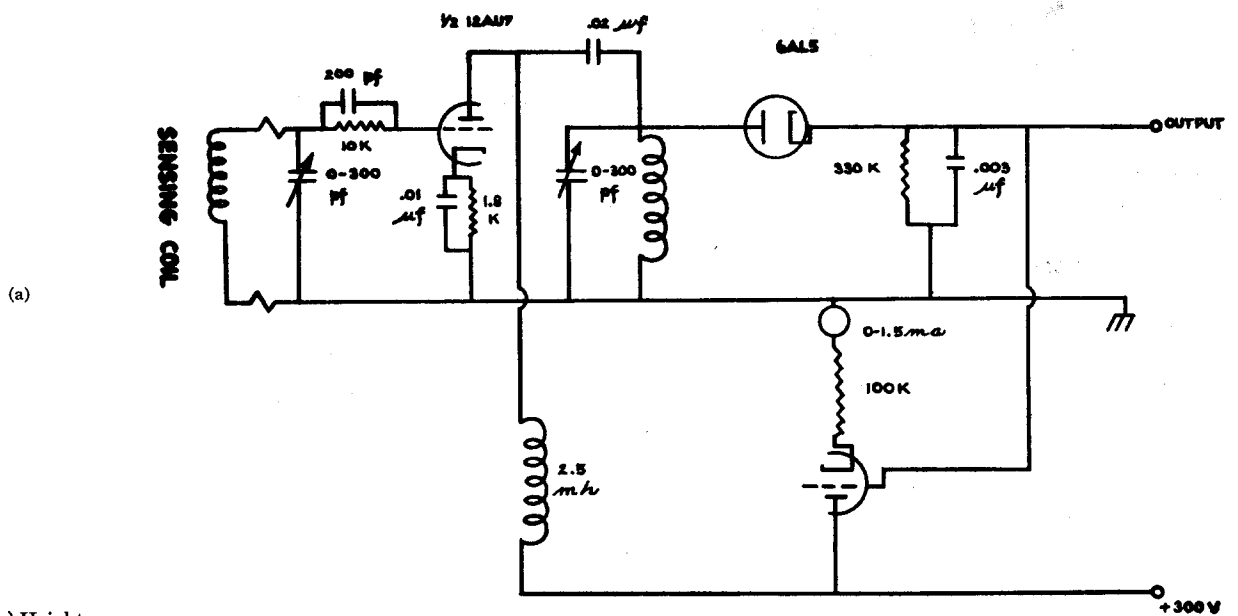

FIG. 3. Second type double magnetic suspension. Top electromagnet exerts upward force. Bottom electromagnet exerts downward force.

⁴ J. W. Beams, Bull. Am. Phys. Soc. 8, 395 (1963).

in the "skirt" where possible. The dotted line V shows the location of the glass vacuum chamber. It, of course, is clear that light beam and photocell or capacitor pickups can be used in place of P₁ and P₂ if desired. The horizontal damping of R₁ also is usually sufficient to damp R₂, although R₂ must be accurately constructed because the magnitude of the damping of R₂ is considerably less than that of R₁. R₁ and R₂ must be designed so that their moments of inertia are greatest about the vertical axis.

A number of different magnetic support circuits may be used. The support circuit E₁ used in this experiment has been described in detail previously.^{2,3} The support circuit E₂ is shown in Fig. 4. Essentially, it is the same as E₁ except that balanced amplifiers and an adjustable reference voltage are introduced to reduce and correct for small rotor drifts. The circuit E₂ was designed and previously used in other experiments at the University of Virginia by D. M. Spitzer, Jr.⁵ It is important to test each circuit



(a)

FIG. 4(a) Height sensing oscillator and detector unit. (b) Servo and power amplifiers.

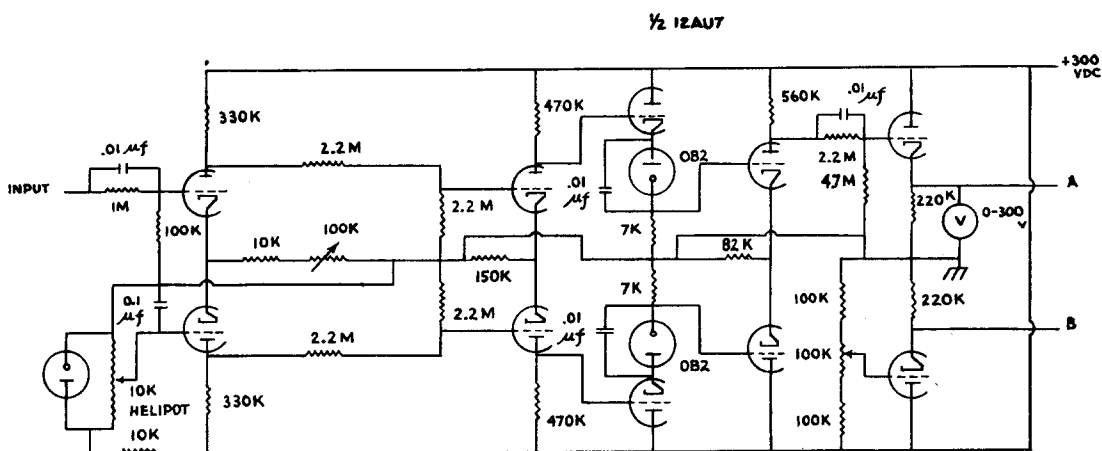

(b)

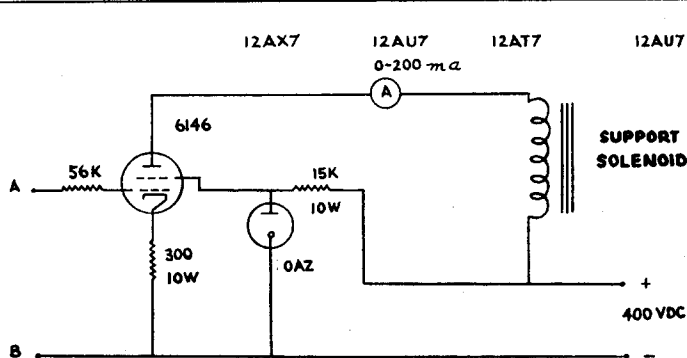

⁵ D. M. Spitzer, Jr., University of Virginia Dissertation, 1962.

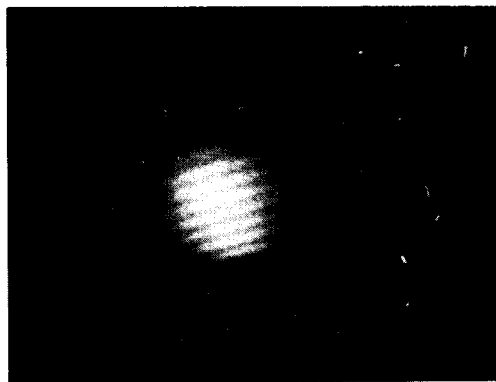

FIG. 5. Photograph of fringes with 5460.7-Å mercury line.

separately by examining the suspended rotor with a microscope for any vertical drift or minute vertical oscillations. A better method is to attach a small mirror to the bottom of a suspended nonspinning rotor which is made to serve as an end mirror of one arm of a Michelson interferometer so oriented that vertical motion of the rotor by one-half wavelength of the light produces a shift of the fringe pattern by one fringe. When the circuits are properly adjusted the fringes should be reasonably sharp showing that the vertical motion is less than the wavelength of light. Figure 5 is a photograph of such fringes. It should be pointed out that it is possible to operate the double magnetic suspension stably even though small vertical drifts and oscillations of the rotors are present. However, to get the lowest rotor deceleration or f/f , oscillations should be absent and the suspension should meet the sharp fringe test described above. The solenoid S_1 contains 40 000 turns of AGW No. 26 copper wire. Its o.d. is 6 in., i.d. 1.5 in., and length 5 in. The core is a solid rod of Swedish iron 7.8 in. long and 0.8 in. in diameter. It is hung as a pendulum from the brass support M by a steel wire. Its lower end dips into a hollow plastic cylinder containing oil as shown in Fig. 2. A thin sheet of aluminum is placed just below the core to prevent the swinging of the core from affecting the pickup coil P_1 . S_2 is carefully aligned so that its magnetic field is symmetrical and its axis is vertical. Solenoid S_2 contains 24 000 turns of AGW No. 27 copper wire. It is accurately wound to give a symmetrical field about its vertical axis. Its o.d. is 7 in., i.d. is 2 in., and the windings are 2 in. high. The position of S_2 is adjusted with the rotor R_1 magnetically suspended by S_1 in such a way that a hand low-power microscope focused on R_1 shows no horizontal motion of R_1 when R_2 is brought into support. The solenoids are mounted by brass and other nonmagnetic supports on a heavy table which rests on partially inflated rubber inner tubes. The electronic circuits are mounted on inflated rubber balloons. Usually, at least two layers of Permalloy sheet are required for magnetic shielding. In some cases, it is necessary to put a thin slightly conducting transparent coating of gold on the inside of the vacuum chamber to serve as a Faraday cage and

to prevent unequal distribution of electrostatic charges. Unless R_1 and R_2 are carefully compensated the temperature must be held constant. So far, the stresses in R_2 have been kept well below one-half of the yield stress in order to reduce creep to a minimum. The ferromagnetic parts of both R_1 and R_2 should be as magnetically soft as possible consistent with mechanical strength. Also, they should be carefully demagnetized before they are placed in the suspension. After being suspended each rotor should be tested for low constant rotation (one revolution/15 min). If oscillations or irregularities in the motion occur they should be demagnetized again, or they should be spun up to speed and then driven back down to rest and the tests repeated, etc.

The double magnetic suspension shown in Fig. 3 differs from that in Figs. 1 and 2. The upper solenoid in supporting the upper rotor induces a magnetic moment in it. As a result the lower rotor when brought near enough to the upper rotor will be supported. However, in order to keep the lower rotor from flying up into the upper rotor, a magnetic field from the lower solenoid is regulated by the lower pickup coil in such a way that the magnetic field increases when the lower rotor moves upward and *vice versa*. This type of double suspension is very stable and easy to adjust especially if the upper rotor has a small residual magnetic moment in the proper direction. However, this suspension has not been used in experiments so far because a small amount of magnetic flux affecting the lower rotor is not rotating. Therefore, it is probably inferior to the support shown in Figs. 1 and 2 for many experiments.

The outer rotor is driven to operating speed by means of a rotating magnetic field located outside V and below S_2 ; i.e., the rotor R_1 acts as a high-resistance armature of an induction motor. The ac drive circuit and associated field coils have been described previously.^{1,6,7} When the "skirt" is on R_1 the inner rotor is accelerated by the residual gas which in the beginning preferably should not be less than 10^{-3} Torr. R_2 also may be accelerated by supporting almost all of its weight magnetically but still allowing it to ride very lightly on the bottom of R_1 until operating speed is reached. R_2 then may be completely suspended magnetically. This latter procedure requires great care in adjusting the circuits.

The deceleration experiments which have been carried out at atmospheric pressure at relatively low rotor speeds and without the vacuum chamber shown in Fig. 2 are, at present, being extended to lower pressures and higher speeds.

I am greatly indebted to F. W. Linke and W. Frewer for the very accurate construction of some of the components of the apparatus.

⁶ J. W. Beams, E. C. Smith, and J. M. Watkins, *J. Soc. Motion Picture Television Engrs.* **58**, 159 (1952).

⁷ J. W. Beams, *Science* **120**, 619 (1954).